

| IN<sup>®</sup> WOODFACE | ECOISO<sup>®</sup> ABL |

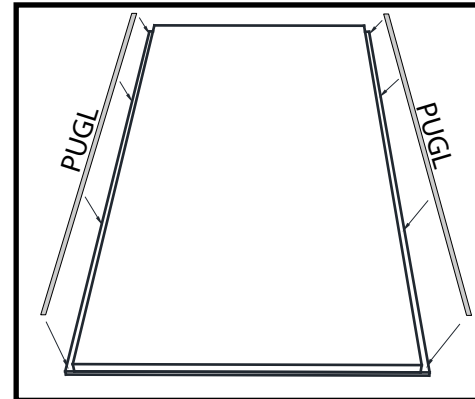

Measure, mark, cut and screw OSB bars onto the wall as shown and accordingly to project requirements. On the back of each panel, apply mounting glue on each side as indicated in gray ("PUGL"). Glue each panel onto the OSB board applying some pressure to it as needed, while protecting front surface finishings. Do the same for the remaining panels.

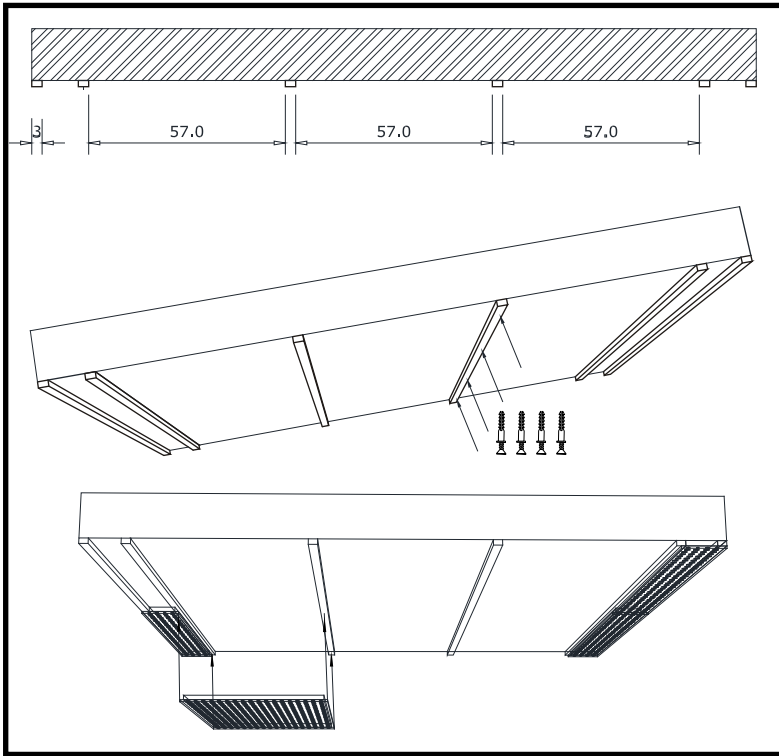
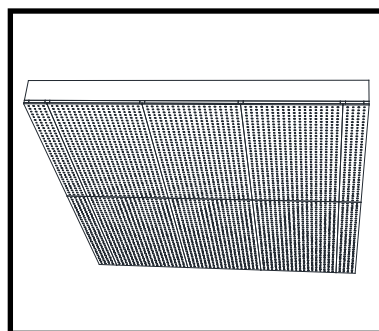
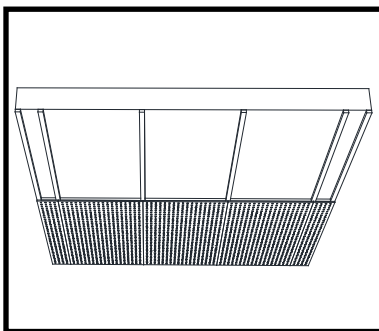
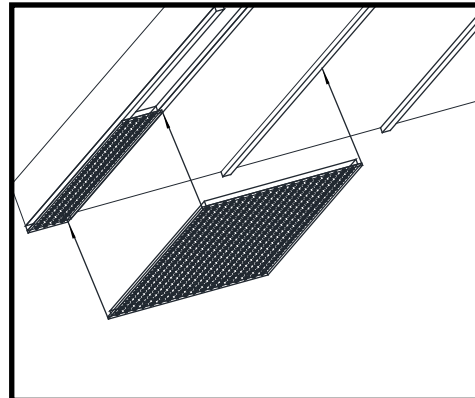
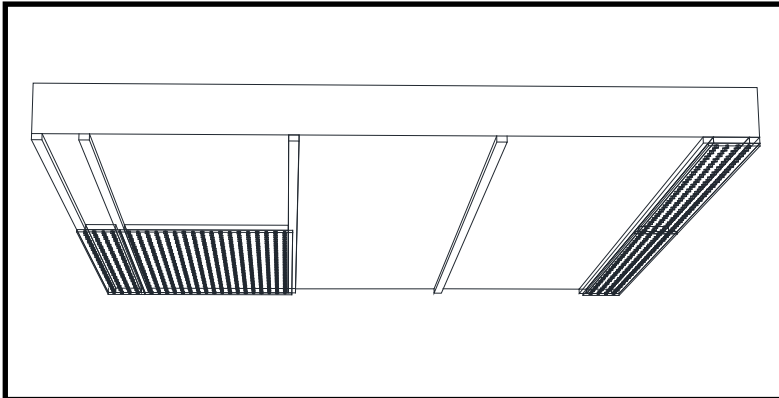

**NOTICE:** If and when necessary, panels can be cut with standard wood cutting tools. For uneven wall dimensions, smaller panel areas are normally installed near the corners for aesthetic reasons. Adhesive time is entirely dependant on the weight of the panel to be glued. Always consult mounting glue specifications. Adhesive gluing times can vary with humidity and temperature. Make sure that the room's temperature and humidity are within the acceptable product values available on our website.

